

Technical data 2023

Inventus Medical and Scientific



PORKKA

SCIENTIFIC
Medical & Research

Technical Data

Inventus Medical & Scientific Equipment

- Excellent product safety for storing temperature-sensitive medicines and storing medicines
 - o High Temperature Protection during defrost period
 - o Temperature deviation of less than 2°C during defrosting, 100g measured by mass
 - o Anti-freeze protection system (chillers)
- Low energy consumption, long life cycle and warranty
 - o Thanks to excellent insulation and vacuum insulation (in some models), energy consumption brings significant savings. Savings in freezer can reach thousands of euros throughout the life cycle of the appliance!
 - o Good isolations and energy-saving components significantly reduce the number of cycles and thus, for example, the compressor's service life is extended. Compressor WARRANTY 5 years for MC and MF models!
 - o Excellent design and high-quality components reduce the need to clean the air filter.
- Hygiene
 - o There are no hard-to-clean holes inside of the cabinet. The shelf guides are drawn to the inside walls of the cabinet, making it very easy to keep the surfaces clean.
 - o There is a pool inside of the cabinet where, due to the breakage of the packaging, liquids can run.
 - o The control unit keyboard and handle of the device are coated with FOTONIT photocatalytic coating

Inventus Scientific devices bring ease of use and save maintenance costs.

Technical Data

Inventus Medical & Scientific Equipment

Contents

Nanoksi Fotonit - touch-safe surfaces	4
Inventus antimicrobial medical refrigerators	5
Inventus medical chillers and freezers	6
Control unit LED numerical display	7
Inventus MC medical chillers	8
Inventus MF medical freezers	10
Inventus MC MF accessories	12
Inventus RC RF spark-proof laboratory refrigeration equipment	14
Inventus RCF spark-proof laboratory refrigeration equipment	16
Inventus RC, RF and RCF accessories	18
Inventus glass shelves	20
Inventus flat bottomed plastic storage boxes (accessory)	21
Sales and delivery conditions	22
Notes	23



Inventus MC 7



Inventus MC 7 GW



Nanoksi Fotonit - touch-safe surfaces

Nanoksi Fotonit is a light-activated antimicrobial photocatalytic coating that changes surfaces to be touch-safe by destroying, e.g., viruses and other pathogens.

The coating has a significant effect on the hygiene and cleanliness of premises and surfaces. Self-disinfecting surfaces remain hygienic without strong chemicals, and the coating is reactivated again and again by light and the coating lasts up to years, depending on consumption.



Nanoksi Fotonit light-protected surfaces make the premises safer for both employees and customers. Protection reduces illness for staff and customers and prevents epidemics with better hygiene.

The photocatalytic **Nanoksi Fotonit** method saves on cleaning and maintenance costs and ensures the cleanliness of rooms and surfaces. Nanoksi Fotonit light-protected surfaces also improve indoor air and thus well-being at work. Applications include, e.g., hospitals, kindergartens, service homes, and laboratories.



Inventus antimicrobial medical refrigerators

Inventus products have been designed to minimize the spread of bacteria and viruses.

In all Inventus products, the door handle (1) and control unit keypad (2) is treated with **Nanoksi Fotonit** photocatalytic coating.

As a factory-fitted accessory, the interior of the device (3) can be treated with a **Nanoksi Fotonit** photocatalytic coating. In this case, the device is also equipped with a disinfection lamp.

Thanks to these treatments, the components of the device are protected against microbes (bacteria, fungi, mold, viruses).



1. Door handle



2. Control unit keypad



3. The interior of the device

Many other surfaces can also be coated with **Nanoksi Fotonit** photocatalytic coating. Request a separate offer from the sales department here!

Nanoksi Fotonit - a light-protected surfaces

Technical Data

Inventus Medical & Scientific Equipment

Inventus medical chillers and freezers

Inventus medical chillers and freezers have been designed to improve product safety in temperature sensitive medicins and in medical storage. They are energy-efficient, safe, and reliable. Products are stored in controlled temperatures required by pharmaceutical manufacturers regardless of variations caused by the refrigeration system or normal usage.

Every care has been taken to ensure that high hygienic levels can be maintained, which include rounded corners and a one piece-dished floor pan as well as our integrated shelf supports all of which avoid dirt traps and make the cabinets easy to deep clean. Also pull out / push in door gaskets makes changing easy and quick.

Besides safe surfaces, internal qualities of the product have been developed to meet the requirements of even the most demanding users. Air circulation in the product has been designed to keep the temperature within $\pm 1^{\circ}\text{C}$ on all shelves.

Additional product safety is provided by anrifreeze protection in medical chillers, and in freezers by a temperature monitor during defrosting.

The clear interface, quieter operating sound, and environmentally friendly and energy-efficient refrigerant R290 hydrocarbon with a very low Global warming potential (GWP) value make it an ecological choice.



Control unit LED numerical display

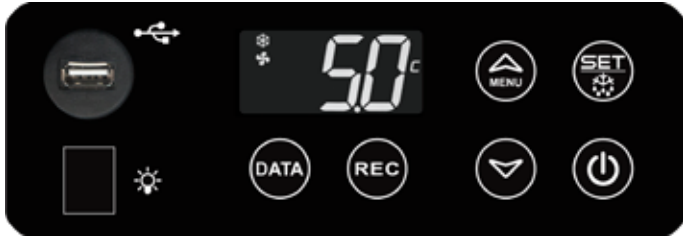

All cabinet models feature a clear and easy-to-use control unit.

All main functions can be performed with one push button: checking of the minimum and maximum temperature, continuous on/off recording of temperature, continuous recording of temperature on a USB flash drive.

- Continuous temperature recording
- USB port for data reading
- Big LED number temperature display
- Battery backup for MED SAVE control unit's power failure alarm and temperature recording for 12 hours (with press switch)
- Complies with the DIN 58345 storage requirements
- Temperature monitor during defrost
- Products are available with optional lockable battery backup switch and anti-freeze protection systems (complies with the requirements DIN 58345 set to storage of pharmaceuticals)
- Versatile features and alarms of MED SAVE control unit are displayed on a large LED screen. If necessary, an acoustic alarm will also produce a sound signal. Potential-free alarm information is transferred to real estate supervision via a control unit. All possible alarms are stored in the memory of the control unit with precise time and alarm information.

Technical Data

Inventus MC medical chillers

Inventus medical chillers have been designed with the needs of hospitals and healthcare institutions in mind as the ideal solution to storing temperature sensitive medicines and vaccines. They are energy efficient, safe and reliable.

The lockable and easy to clean Inventus MC medical chiller standard setup includes four glass shelves adjustable in 56 mm intervals.

Features

- Excellent temperature uniformity ($\pm 1^{\circ}\text{C}$) measured according to DIN 58345
- Low noise level, under 49 dB(A)
- Control unit with clear numeric display for temperature and other functions
- 12-hour battery backup for control unit's power failure alarm and temperature recording (DIN 58345 requirement)
- Antimicrobial (Nanoksi Fotonit) coated controller keyboard
- Real time temperature recording and USB port for data reading
- Key lock on the control unit
- Recording of maximum and minimum temperature
- Visual and audible high/low temperature alarm
- Door switch for fan control and door open-alarm
- Probe failure alarm
- Readiness for RS485 adapter for computer connection
- Potential free (no voltage) alarm coupling readiness for real estate monitoring
- 50 ml bottle for a temperature sensor P4 inside the cabinet
- Fan assisted air distribution
- Anti-freeze protection
- Automatic defrost
- High Temperature Protection during defrost period
- Automatic vaporization of condensed water
- Molded eco-friendly polyurethane insulated frame. The insulation thickness is 80-100 mm
- External finish has a white polyester coated sheet steel. Interior finish in stainless steel grade AISI 304
- 4 glass shelves (maximum load 50 kg / shelf) which are adjustable in increments of 56 mm
- Abloy lock is placed in front panel for easy maintenance (Abloy Sentry key)
- The self-closing door has a sturdy molded handle, magnetic seal, and durable hinges. The door remains open at a 90 degree angle
- Antimicrobial (Nanoksi Fotonit) coated handle is designed as a solid part of the door
- Stainless steel legs, height adjustable from 130 mm to 205 mm
- Efficient, environmental friendly, energy saving R290 refrigerant
- Electrical supply 230V / 50 Hz



Accessories

- Additional shelves
- Wire basket
- Plastic storage box set
- Castors, lockable front castors
- Shorter stainless steel legs, adjustable from 80 mm to 105 mm
- Door opening pedal
- $\varnothing 8$ mm sleeved access port for additional probe
- LED light (standard in GW models)
- iLOQ lock (Abloy as a standard)
- DIN accessory package (lockable battery backup switch)

Technical Data

Inventus MC medical chillers

**R290
Refrigerant**

Inventus			MC 6	MC 7	MC 8	MC 6 GW	MC 7 GW	MC 8 GW
External dimensions	Width	mm	600	730	850	600	730	850
	Depth	mm	760	870	750	760	870	750
	Height	mm	2100	2100	2100	2100	2100	2100
Internal dimensions	Width *	mm	404	534	654	404	534	654
	Depth	mm	610	675	555	610	675	555
	Height	mm	1485	1485	1485	1485	1485	1485
Volume (measured on a SS shelf according to DIN standard)	Net	liters	331	489	491	331	489	491
	Gross	liters	421	609	619	421	609	619
Weight	Net	kg	132	152	152	137	157	157
Package weight	Gross	kg	142	162	162	147	167	167
Package size	Width	mm	650	780	900	650	780	900
	Depth	mm	800	920	800	800	920	800
	Height	mm	2250	2250	2250	2250	2250	2250
Sound level measured at the distance of 1m and from the height of 1.6 m		dB	49	49	49	49	49	49
Operating temperature		°C	+2...+15 °C	+2...+15 °C	+2...+15 °C	+2...+15 °C	+2...+15 °C	+2...+15 °C
Ambient temperature		°C	+10...+35 °C	+10...+35 °C	+10...+35 °C	+10...+35 °C	+10...+35 °C	+10...+35 °C
Temperature accuracy		°C	DIN58345	DIN58345	DIN58345	DIN58345	DIN58345	DIN58345
Refrigerant	(g)/GWP	g	R290/115 g (GWP 3)	R290/110 g (GWP 3)	R290/110 g (GWP 3)	R290/115 g (GWP 3)	R290/110 g (GWP 3)	R290/110 g (GWP 3)
Connection Power		kW	0.5	0.5	0.5	0.5	0.5	0.5
Fuse	Slow	A	10	10	10	10	10	10
Voltage		V	230/50 Hz	230/50 Hz	230/50 Hz	230/50 Hz	230/50 Hz	230/50 Hz
Defrost 1. Air 2. Hot gas 3. Electric			1	1	1	1	1	1
Energy consumption (GW LED light OFF/ON)		kWh/year	208	239	237	350	409	409
Energy consumption (GW LED light OFF/ON)		kWh/d	0.569	0.654	0.65	0.96	1.12	1.12
Shelves (width x depth)		mm	400 x 600	530 x 650	650 x 530	400 x 600	530 x 650	650 x 530
Shelf amount standard/maximum		pcs	4 / 24	4 / 24	4 / 24	4 / 24	4 / 24	4 / 24



* Free width = shelf width -20 mm

Technical Data

Inventus MF medical freezers

Inventus medical freezers have been designed with the needs of hospitals and healthcare institutions in mind as the ideal solution to storing temperature sensitive medicins. They are energy efficient, safe and reliable.

The lockable and easy to clean Inventus MC medical freezer standard setup includes four glass shelves adjustable in 56 mm intervals.

Inventus medical freezers have an automatic defrosting functionality with an excellent steadiness of temperature uniformity.

Features

- Excellent temperature uniformity ($\pm 1^{\circ}\text{C}$)
- Low noise level, under 50 dB(A)
- Control unit with clear numeric display for temperature and other functions
- 12-hour battery backup for control unit's power failure alarm and temperature recording (DIN 58345 requirement)
- Antimicrobial (Nanoksi Fotonit) coated controller keyboard
- Real time temperature recording and USB port for data reading
- Key lock on the control unit
- Recording of maximum and minimum temperature
- Visual and audible high/low temperature alarm
- Door switch for fan control and door open-alarms
- Probe failure alarm
- Readiness for RS485 adapter for computer connection
- Potential free (no voltage) alarm coupling readiness for real estate monitoring
- 50 ml bottle for a temperature sensor P4 inside the cabinet
- Fan assisted air distribution
- Automatic defrost
- High Temperature Protection during defrost period
- Automatic vaporization of condensed water
- Molded eco-friendly polyurethane insulated frame. The insulation thickness is 80-100 mm
- External finish has a white polyester coated sheet steel. Interior finish in stainless steel grade AISI 304
- 4 glass shelves (maximum load 50 kg / shelf) which are adjustable in increments of 56 mm
- Abloy lock is placed in front panel for easy maintenance (Abloy Sentry key)
- The self-closing door has a sturdy molded handle, magnetic seal, and durable hinges. The door remains open at a 90 degree angle
- Antimicrobial (Nanoksi Fotonit) coated handle is designed as a solid part of the door
- Stainless steel legs, height adjustable from 130 mm to 205 mm
- Efficient, environmental friendly, energy saving R290 refrigerant
- Electrical supply 230V / 50 Hz

Accessories

- Additional shelves
- Wire basket
- Flat bottomed plastic storage box set
- Castors, lockable front castors
- Short stainless steel legs, adjustable from 80 mm to 105 mm
- Door opening pedal
- \varnothing 8 mm sleeved access port for additional probe
- LED light
- iLOQ lock (Abloy as a standard)
- DIN accessory package (lockable battery backup switch)

Technical Data

Inventus MF medical freezers

R290
Refrigerant

Inventus			MF 6	MF 7	MF 8
External dimensions	Width	mm	600	730	850
	Depth	mm	760	870	750
	Height	mm	2100	2100	2100
Internal dimensions	Width *	mm	404	534	654
	Depth	mm	610	675	555
	Height	mm	1485	1485	1485
Volume (measured on a SS shelf according to DIN standard)	Net	liters	331	489	491
	Gross	liters	421	609	619
Weight	Net	kg	132	152	152
Package weight	Gross	kg	142	162	162
Package size	Width	mm	650	780	900
	Depth	mm	800	920	800
	Height	mm	2250	2250	2250
Sound level measured at the distance of 1m and from the height of 1.6 m		dB	50	50	50
Operating temperature		°C	-26...-15 °C	-26...-15 °C	-26...-15 °C
Ambient temperature		°C	+10...+35 °C	+10...+35 °C	+10...+35 °C
Temperature accuracy 100 g mass		°C	±1°C	±1°C	±1°C
Refrigerant	(g)/GWP	g	R290/83 (GWP 3)	R290/90 (GWP 3)	R290/90 (GWP 3)
Connection Power		kW	0.5	0.5	0.5
Fuse	Slow	A	10	10	10
Voltage		V	230V/50Hz	230V/50Hz	230V/50Hz
Defrost 1. Air 2. Hot gas 3. Electric			2	2	2
Energy consumption (GW LED light OFF/ON)		kWh/year	837	928	894
Energy consumption (GW LED light OFF/ON)		kWh/d	2.293	2.542	2.45
Shelves (width x depth)		mm	400 x 600	530 x 650	650 x 530
Shelf amount standard/maximum		pcs	4 / 24	4 / 24	4 / 24



Inventus MF 6



Inventus MF 7



Inventus MF 8

* Free width = shelf width -20 mm

Technical Data

Inventus MC MF accessories

APF19010	Ø 8 MM SLEEVED ACCESS PORT FOR ADDITIONAL PROBE (ADDITION TO INSTALLATION DEPTH: MODEL 6 +25 MM, MODELS 7 AND 8 +35 MM)
APF19022	PROBE PT100 TF14 (CABLE 3 M)
APC12030	JUNCTION BOX AND CONNECTED ALARM CABLE (2.5 M) WITH RJ45 PLUG
APF19021	CENTRAL ALARM JUNCTION BOX
APC12100	TTL/RS-485 DATA CABLE 0.5 M
APC12300	GROUNDING CABLE
APF19020	DIN ACCESSORY PACKAGE (LOCKABLE BATTERY BACKUP SWITCH)
APF19000	ELECTRONIC LOCK iLOQ S10 + ONE KEY Further information: www.iloq.com
APM20605	iLOQ S10 ADDITIONAL KEY Further information: www.iloq.com
APF19001	ELECTRONIC LOCK iLOQ S5+ ONE KEY Further information: www.iloq.com
6300221	iLOQ S5 ADDITIONAL KEY Further information: www.iloq.com
APF10320	STAINLESS STEEL PANEL SHELF 6
API10103	STAINLESS STEEL WIRE SHELF 6
API10112	GLASS SHELF 6
API10106	STAINLESS STEEL BOTTOM WIRE SHELF 6
APF10520	STAINLESS STEEL PANEL SHELF 7
API10104	STAINLESS STEEL WIRE SHELF 7
API10113	GLASS SHELF 7
API10107	STAINLESS STEEL BOTTOM WIRE SHELF 7
APF11020	STAINLESS STEEL WIRE BASKET 7
APF10420	STAINLESS STEEL PANEL SHELF 8
API10105	STAINLESS STEEL WIRE SHELF 8
API10114	GLASS SHELF 8
API10108	STAINLESS STEEL BOTTOM WIRE SHELF 8
EF3226-INV7	STAINLESS STEEL WIRE BASKET 8
APF19032	FLAT BOTTOMED PLASTIC STORAGE BOX 6, ONE SHELF SET 150 x 600 x 90 MM (2 PCS)
APF19031	FLAT BOTTOMED PLASTIC STORAGE BOX 7, ONE SHELF SET 230 x 600 x 90 MM (2 PCS)
APF19030	FLAT BOTTOMED PLASTIC STORAGE BOX 8, ONE SHELF SET 230 x 500 x 90 MM (2 PCS) + 150 x 500 x 90 MM (1 PCS)
EF3582	HYGIENIC ROOFING 6
EF3580	HYGIENIC ROOFING 7
EF3581	HYGIENIC ROOFING 8
APF16600	LED LIGHT
APF13800	CASTORS, LOCKABLE FRONT CASTORS WHEN CABINET HEIGHT = 2080 MM
APF13200	SHORT STAINLESS STEEL LEGS, ADJUSTABLE FROM 80 MM TO 105 MM WHEN CABINET HEIGHT = 2050 MM
APF12400	DOOR OPENING PEDAL
APF19040	NANOKSI FOTONIT COATING WITH DISINFECTING LIGHT
APF19041	NANOKSI FOTONIT COATING WITH DISINFECTING LIGHT (GW MODELS)
API10050	HDR TEMPERATURE RANGE +2...+6 °C (MC)

Technical Data

Inventus MC MF accessories



JUNCTION BOX AND CONNECTED ALARM CABLE (2.5 M) WITH RJ45 PLUG



CENTRAL ALARM JUNCTION BOX



TTL/RS-485 DATA CABLE 0.5 M



iLOQ LOCK



STAINLESS STEEL PANEL SHELF



STAINLESS STEEL WIRE SHELF



GLASS SHELF

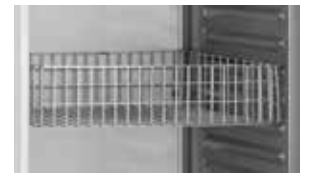

STAINLESS STEEL WIRE BASKET



FLAT BOTTOMED PLASTIC STORAGE BOX



HYGIENIC ROOFING



LED LIGHT



CASTORS



SHORT STAINLESS STEEL LEGS



DOOR OPENING PEDAL

Technical Data

Inventus RC RF spark-proof laboratory refrigeration equipment

Inventus RC ja RF research and test cabinets have been designed for laboratories, health care and biosciences.

Standard setups of lockable and easy to clean Inventus RC and RF cabinets include four glass shelves adjustable in 56 mm intervals.

**SPARK
PROOF
INTERIOR**

Features

- Excellent temperature uniformity ($\pm 1^{\circ}\text{C}$) measured from 100 g mass
- Low noise level, under 49 dB(A)
- Control unit with clear numeric display for temperature and other functions
- 12-hour battery backup for control unit's power failure alarm and temperature recording
- Antimicrobial (Nanoksi Fotonit) coated controller keyboard
- Real time temperature recording and USB port for data reading
- Key lock on the control unit
- Recording of maximum and minimum temperature
- Visual and audible high/low temperature alarm
- Door switch for fan control and door open-alarms
- Probe failure alarm
- Readiness for RS485 adapter for computer connection
- Potential free (no voltage) alarm coupling readiness for real estate monitoring
- 50 ml bottle for a temperature sensor P4 inside the cabinet
- Fan assisted air distribution
- Automatic defrost
- Overheat protection (RC)
- Automatic vaporization of condensed water
- Molded eco-friendly polyurethane insulated frame. The insulation thickness is 80-100 mm
- External finish has a white polyester coated sheet steel or stainless steel. Interior finish in stainless steel grade AISI 304
- 4 glass shelves are adjustable in increments of 56 mm
- Abloy lock is placed in front panel for easy maintenance (Abloy Sentry key)
- The self-closing door has a sturdy molded handle, magnetic seal, and durable hinges. The door remains open at a 90 degree angle
- Antimicrobial (Nanoksi Fotonit) coated handle is designed as a solid part of the door
- Stainless steel legs, height adjustable from 130 mm to 205 mm
- Efficient, environmental friendly, energy saving R290 refrigerant
- Electrical supply 230V / 50 Hz



Accessories

- Additional shelves
- Flat bottomed plastic storage box set
- Stainless steel wire basket
- Castors, lockable front castors
- Short stainless steel legs, adjustable from 80 mm to 105 mm
- Door opening pedal
- $\varnothing 8$ mm sleeved access port for additional probe
- LED light (standard in GW models)
- iLOQ lock (Abloy as a standard)

Technical Data

R290
Refrigerant

Inventus RC CF spark-proof laboratory refrigeration equipment

Inventus			RC 6	RC 8	RC 6 GW	RC 8 GW	RF 6	RF 8
External dimensions	Width	mm	600	850	600	850	600	850
	Depth	mm	760	750	760	750	760	750
	Height	mm	2100	2100	2100	2100	2100	2100
Internal dimensions	Width	mm	404	654	404	654	404	654
	Depth	mm	610	555	610	555	610	555
	Height	liters	1485	1485	1485	1485	1485	1485
Volume (measured according to DIN standard)	Net	liters	331	491	331	491	331	491
	Gross	kg	421	619	421	619	421	619
Weight	Net	kg	132	152	137	157	132	152
Package weight	Gross	mm	142	162	147	167	142	162
Package size	Width	mm	650	900	650	900	650	900
	Depth	mm	800	800	800	800	800	800
	Height	mm	2250	2250	2250	2250	2250	2250
Sound level measured at the distance of 1m / from the height of 1.6 m		dB	49	49	49	49	50	50
Operating temperature		°C	+2...+40 °C	+2...+40°C	+2...+40 °C	+2...+40°C	-32...-15 °C	-32...-15 °C
Ambient temperature		°C	+10...+35 °C	+10...+35 °C	+10...+35 °C	+10...+35 °C	+10...+35 °C	+10...+35 °C
Temperature accuracy		°C	±1	±1	±1	±1	±1	±1
Refrigerant	(g)/GWP	g	R290/115 g (GWP 3)	R290/110 g (GWP 3)	R290/115 g (GWP 3)	R290/110 g (GWP 3)	R290/83 g (GWP 3)	R290/90 g (GWP 3)
Connection Power		kW	0.5	0.5	0.5	0.5	0.65	0.75
Fuse	Slow	A	10	10	10	10	10	10
Voltage		V	230/50 Hz	230/50 Hz	230/50 Hz	230/50 Hz	230V/50Hz	230V/50Hz
Defrost 1. Air 2. Hot gas 3. Electric			1	1	1	1	2	2
Energy consumption		kWh/year						
Energy consumption		kWh/d						
Shelves (width x depth)		mm	400 x 600	650 x 530	400 x 600	650 x 530	400 x 600	650 x 530
Shelf amount standard/maximum		pcs	4 / 14	4 / 24	4 / 24	4 / 24	4 / 24	4 / 24



Inventus RC 6, RF 6



Inventus RC 8, RF 8



Inventus RC 6 GW



Inventus RC 8 GW

Technical Data

Inventus RCF spark-proof laboratory refrigeration equipment

Inventus RCF research and test cabinets have been designed specially for test laboratory needs like component testing.

Standard setup of lockable and easy to clean Inventus RCF cabinet includes four glass shelves adjustable in 56 mm intervals.

**SPARK
PROOF
INTERIOR**

Features

- Excellent temperature uniformity
- Low noise level, under 49 dB(A)
- Control unit with clear numeric display for temperature and other functions
- 12-hour battery backup for control unit's power failure alarm and temperature recording
- Antimicrobial (Nanoksi Fotonit) coated controller keyboard
- Real time temperature recording and USB port for data reading
- Key lock on the control unit
- Recording of maximum and minimum temperature
- Visual and audible high/low temperature alarm
- Door switch for fan control and door open-alarms
- Probe failure alarm
- Readiness for RS485 adapter for computer connection
- Potential free (no voltage) alarm coupling readiness for real estate monitoring
- 50 ml bottle for a temperature sensor P4 inside the cabinet
- Fan assisted air distribution
- Automatic defrost
- Overheat protection (RC, RCF)
- Automatic vaporization of condensed water
- Molded eco-friendly polyurethane insulated frame. The insulation thickness is 80-100 mm
- External finish has a white polyester coated sheet steel or stainless steel. Interior finish in stainless steel grade AISI 304
- 4 glass shelves are adjustable in increments of 56 mm
- Abloy lock is placed in front panel for easy maintenance (Abloy Sentry key)
- The self-closing door has a sturdy molded handle, magnetic seal, and durable hinges. The door remains open at a 90 degree angle
- Antimicrobial (Nanoksi Fotonit) coated handle is designed as solid part of the door
- Stainless steel legs, height adjustable from 130 mm to 205 mm
- Efficient, environmental friendly, energy saving R290 refrigerant
- Electrical supply 230V / 50 Hz



Accessories

- Additional shelves
- Flat bottomed plastic storage box set
- Stainless steel wire basket
- Castors, lockable front castors
- Short stainless steel legs, adjustable from 80 mm to 105 mm
- Door opening pedal
- ø 8 mm sleeved access port for additional probe
- LED light
- iLOQ lock (Abloy as a standard)

Inventus RCF spark-proof laboratory refrigeration equipment

Inventus			RCF 6	RCF 8
External dimensions	Width	mm	600	850
	Depth	mm	760	750
	Height	mm	2100	2100
Internal dimensions	Width	mm	404	654
	Depth	mm	610	555
	Height	liters	1485	1485
Volume (measured according to DIN standard)	Net	liters	331	491
	Gross	kg	421	619
Weight	Net	kg	132	152
Package weight	Gross	mm	142	162
Package size	Width	mm	650	900
	Depth	mm	800	800
	Height	mm	2250	2250
Sound level measured at the distance of 1m / from the height of 1.6 m		dB	49	49
Operating temperature		°C	-10...+55 °C	-10...+55 °C
Ambient temperature		°C	+10...+30 °C	+10...+30 °C
Temperature accuracy		°C	±2	±2
Refrigerant	(g)/GWP	g	R290/115 g (GWP 3)	R290/110 g (GWP 3)
Connection Power		kW	0.5	0.5
Fuse	Slow	A	10	10
Voltage		V	230/50 Hz	230/50 Hz
Defrost 1. Air 2. Hot gas 3. Electric			2	2
Shelves (width x depth)		mm	400 x 600	650 x 530
Shelf amount standard/maximum		pcs	4	4



Inventus RCF6



Inventus RCF8

Technical Data

Inventus RC, RF and RCF accessories

APF19010	Ø 8 MM SLEEVED ACCESS PORT FOR ADDITIONAL PROBE (ADDITION TO INSTALLATION DEPTH: MODEL 6 +25 MM, MODEL 8 +35 MM)
APF19022	PROBE PT100 TF14 (CABLE 3 M)
APC13010	ANTI-FREEZE PROTECTION (RC)
APC12030	JUNCTION BOX AND CONNECTED ALARM CABLE (2.5 M) WITH RJ45 PLUG
APF19021	CENTRAL ALARM JUNCTION BOX
APC12100	TTL/RS-485 DATA CABLE 0.5 M
APC12300	GROUNDING CABLE
APF19000	ELECTRONIC LOCK iLOQ S10 (INCLUDES ONE KEY)
APM20605	iLOQ S10 ADDITIONAL KEY
APF19001	ELECTRONIC LOCK iLOQ S5+ ONE KEY Further information: www.iloq.com
6300221	iLOQ S5 ADDITIONAL KEY Further information: www.iloq.com
APF10320	STAINLESS STEEL PANEL SHELF 6
API10103	STAINLESS STEEL WIRE SHELF 6
API10112	GLASS SHELF 6
API10106	STAINLESS STEEL BOTTOM WIRE SHELF 6
APF10420	STAINLESS STEEL PANEL SHELF 8
API10105	STAINLESS STEEL WIRE SHELF 8
API10114	GLASS SHELF 8
API10108	STAINLESS STEEL BOTTOM WIRE SHELF 8
EF3226-INV7	STAINLESS STEEL WIRE BASKET 8
APF19032	FLAT BOTTOMED PLASTIC STORAGE BOX 6, ONE SHELF SET 150 x 600 x 90 MM (2 PCS)
APF19030	FLAT BOTTOMED PLASTIC STORAGE BOX 8, ONE SHELF SET 230 x 500 x 90 MM (2 PCS) + 150 x 500 x 90 MM (1 PCS)
APF16600	LED LIGHT
APF13800	CASTORS, LOCKABLE FRONT CASTORS WHEN CABINET HEIGHT = 2080 MM
APF13200	SHORT STAINLESS STEEL LEGS, ADJUSTABLE FROM 80 MM TO 105 MM WHEN CABINET HEIGHT = 2050 MM
APF12400	DOOR OPENING PEDAL
APF19040	NANOKSI FOTONIT COATING WITH DISINFECTING LIGHT
APF19041	NANOKSI FOTONIT COATING WITH DISINFECTING LIGHT (GW MODELS)
API10051	HDF TEMPERATURE RANGE -32...-27 °C (RF)

Technical Data

Inventus RC, RF and RCF accessories



JUNCTION BOX AND CONNECTED ALARM CABLE
(2.5 M) WITH RJ45 PLUG



CENTRAL ALARM JUNCTION BOX



TTL/RS-485 DATA CABLE 0.5 M



iLOQ LOCK



STAINLESS STEEL PANEL SHELF

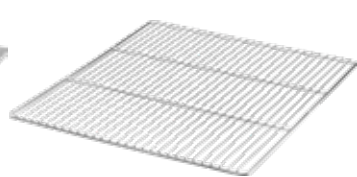

STAINLESS STEEL WIRE SHELF



GLASS SHELF

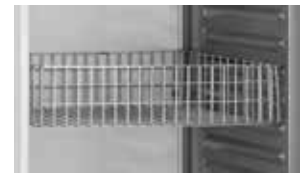

STAINLESS STEEL WIRE BASKET 8



FLAT BOTTOMED PLASTIC STORAGE BOX



HYGIENIC ROOFING



LED LIGHT



CASTORS



SHORT STAINLESS STEEL LEGS



DOOR OPENING PEDAL

Technical Data

Inventus glass shelves

GLASS SHELVES AMOUNT / CABINET	MAXIMUM STORAGE HEIGHT BETWEEN SHELVES
4 (standard amount)	327 mm
5	215 mm
8	159 mm
12	103 mm
24	47 mm

* Shelf bracket space 56 mm

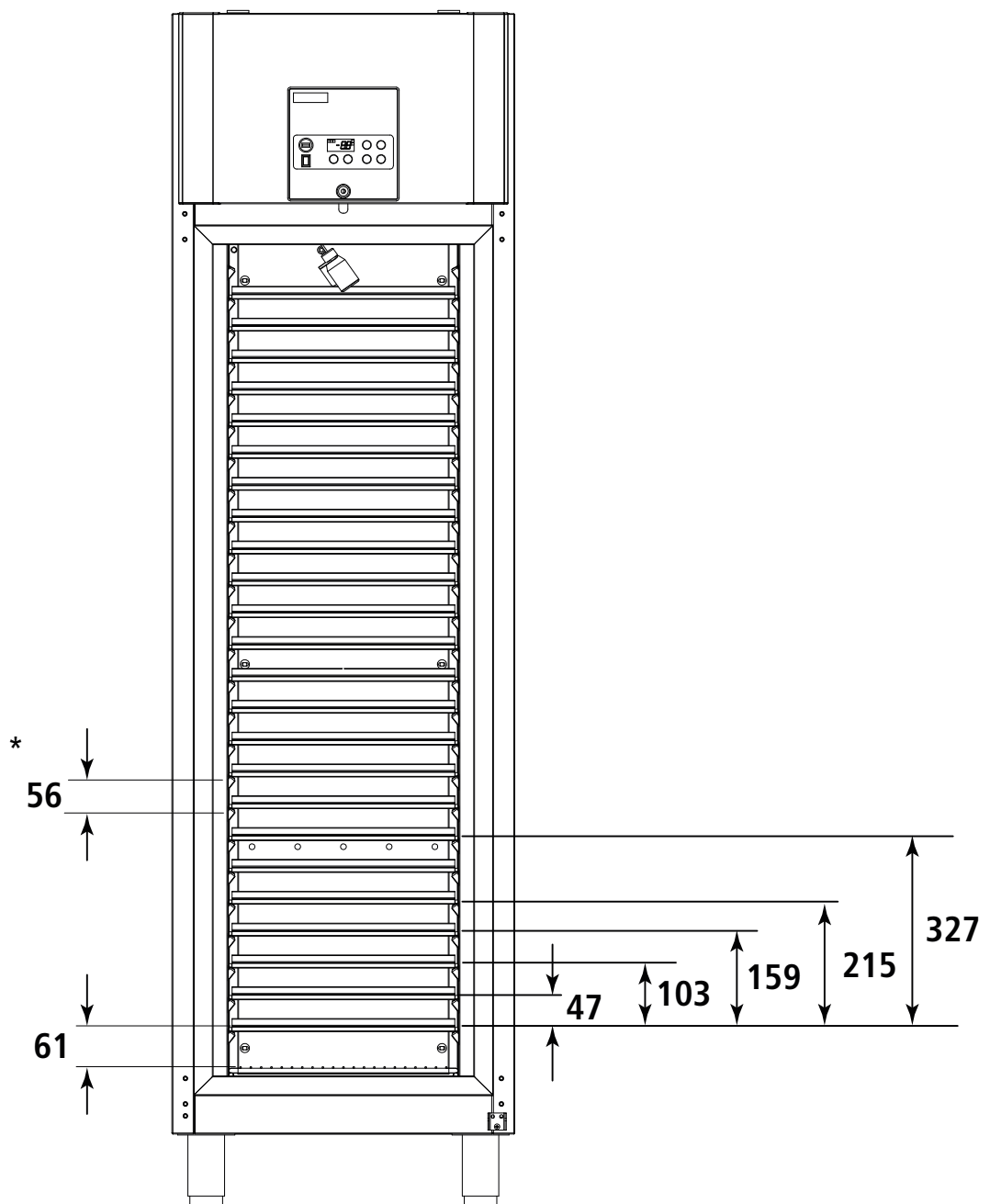

Technical Data

Inventus flat bottomed plastic storage boxes (accessory)

APF19032	FLAT BOTTOMED PLASTIC STORAGE BOX 6, ONE SHELF SET 150 x 600 x 90 MM (2 PCS)
APF19031	FLAT BOTTOMED PLASTIC STORAGE BOX 7, ONE SHELF SET 230 x 600 x 90 MM (2 PCS)
APF19030	FLAT BOTTOMED PLASTIC STORAGE BOX 8, ONE SHELF SET 230 x 500 x 90 MM (2 PCS) + 150 x 500 x 90 MM (1 PCS)

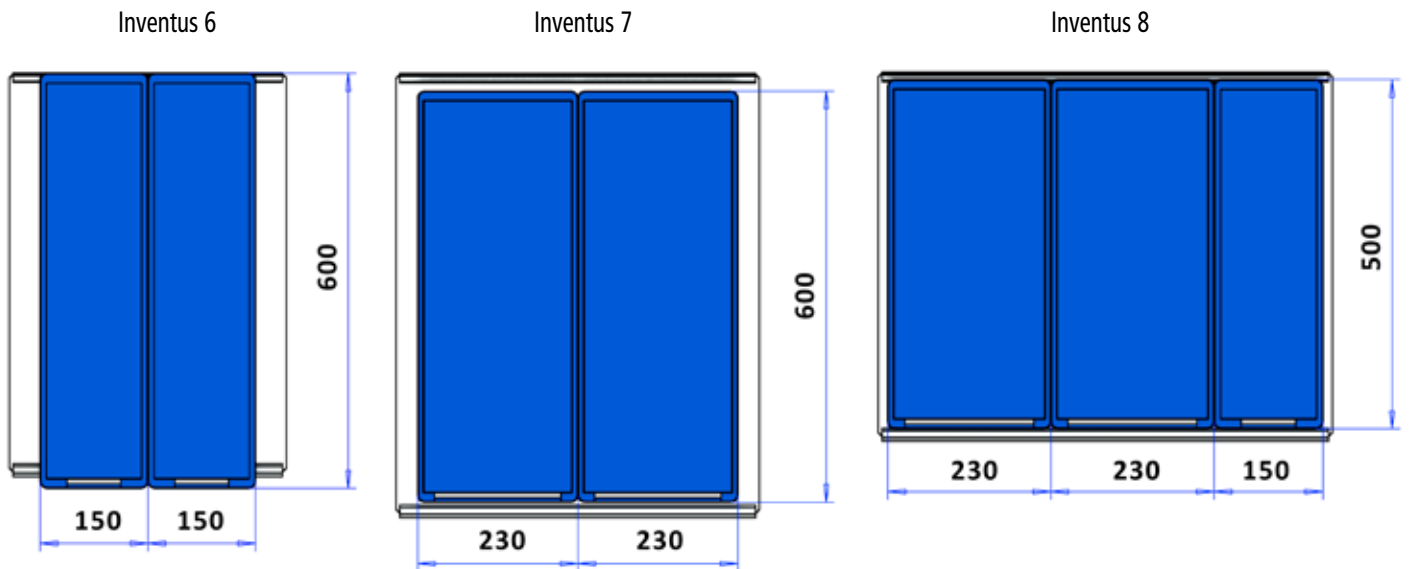

Technical Data

Sales and delivery conditions

1. Prices

Prices are exclusive of VAT. We reserve the right to change prices if the state authorities by changing foreign exchange rates or other charges impact the price determining principles or in case of increase in costs for reasons beyond our control.

2. Deliveries

Terms of delivery is, if not separately agreed, EXW (Ex Works) Ylöjärvi Finland. Standard packaging is included in the prices. If desired, we offer IPPC packaging and freight costs which will be separately priced. Prices do not include waste management arrangements and the cost of recovery of waste. Under the law, the holder of the waste is responsible for the WEEE waste in professional use.

3. Product features

For the purpose of continuous product development, Suomen Kotikylmiö reserves the right to change the products.

4. Changes and cancellations concerning orders

The buyer shall promptly notify in writing the seller of any changes and cancellations. Changes or cancellations must be made fourteen days (14) days before the scheduled delivery time. The seller shall be entitled to invoice the buyer; the value of the current level of preparedness of a product cancelled or changed later than fourteen (14) days. The new delivery time of the changed order will be counted from the date of the change, unless otherwise agreed.

5. Return policy

The seller will not accept returns without prior agreement. The comments regarding the merchandise must be made within five (5) days of receipt. Returns must always be agreed upon in advance with the representative. For the return of standard products, which is not due to the seller's fault, up to 80% will be refunded. Return policy applies only to the products included in the standard sales program with no additional accessories that are unused, undamaged and in their original packaging.

6. Insurance

The customer is responsible for the transportation of goods and transport insurance.

7. Warranty

The warranty period for the raw materials and components is two (2) years if not agreed otherwise. The warranty applies to the equipment sold to the first buyer, i.e. goods have left the factory. The warranty does not cover wear and conditions caused by normal use or the batteries of the appliance.

Warranty is conditional upon the fact that:

- The product is installed in accordance with the provided installation instructions
- The product is used only for its intended purpose
- The product has been used and maintained according to the instructions
- Maintenance work shall be done by a professional refrigeration contractor

Warranty claims must contain:

- Product brand, model and serial number
- Nature of the problem and the circumstances how it has occurred

Technical Data

Notes

R290
Refrigerant

PORKKA

Porkka Finland Oy is an internationally renowned designer and manufacturer of professional refrigeration solutions.

The main areas of activity are HoReCa, medical and research and marine. Porkka is part of the Finnish Festivo-Porkka Group.

The Porkka brand is known for its quality and reliability - the long life cycle of the products, high quality and technical know-how. Porkka's success is based on decades of experience, customer-centric design and continuous product development. The materials used in Porkka products are as recyclable and environmentally friendly as possible. The recyclability of our products is over 95%.



Porkka's solutions are designed and manufactured in accordance with the quality standard ISO 9001: 2015. Porkka's quality system has been certified by Lloyd's Register. Porkka also has an environmental certificate ISO 14001: 2015 issued by LRQA.

We reserve the right to make changes without prior notice.

PORKKA FINLAND OY
Ravitie 3
FI-15680 Hollola, Finland
Tel. +358 10 201 9200
www.porkka.fi

COLIA SCANDINAVIA AB
Bråtagatan 8A
SE-619 33 Trosa, Sweden
Tel. +46 156 67 57 00
www.porkka.se

COLIA AS NORWAY
Ringeriksveien 16
NO-3414 Lierstranda, Norway
Tel. +47 66 98 77 77
www.porkka.no

PORKKA UK & IRELAND
Watford Business Park, Watford
Hertfordshire, WD18 8YB, UK
Tel. +44 1923 233675
www.porkka.co.uk