

PORKKA

HOTEL, RESTAURANT & CATERING
Blast Chillers / Blast Freezer rooms

Brochure 2026

BC Blast Chiller rooms, BC/BF Blast Freezer rooms

ENGLISH



BC and BC/BF 960, BC and BC/BF 990

Blast chiller and blast chiller/freezer rooms for trolley operation

Porkka has a wide range of BC blast chill rooms and combined BC/BF blast chill and freezer rooms for a wide range of uses. Trolley operated models are available in several different sizes, both as a single-door and passthrough model.

GN 1/1 trolleys are suitable for use in BC and BC/BF 960 and BC and BC/BF 990 rooms. BC/BF models have an insulated floor with an optional ramp. All of these models are delivered ready for a central cooling unit connection. The equipment requires drainage for defrost water. The range includes models for both HFC and R744 (CO₂) refrigerants.

FEATURES

- Soft-hard process control for blast chilling/freezing
- Controller programmed for blast chilling and freezing for 4 quick programs and with ability to store 12 customized settings
- Convenient single product probe for precise and accurate soft chilling
- Storage function
- Audible and visual local alarms for HACCP purposes
- Exterior / Interior finish and chassis in stainless steel
- HFC-free polyurethane insulation, thickness 80 mm
- Doors are supplied complete with heavy duty hinges and a lockable door handle which is complete with emergency entrapment release
- Durable gaskets provide a good air seal
- BC versions are supplied without floor, to allow simple trolley operation
- BC/BF chiller/freezer models are supplied with floor equipped with a non-slip stainless steel finish
- Electrical supply 230V/50Hz

OPTIONAL ACCESSORIES

- PORKKA BLUE combined disinfectant and lamp evaporator for disinfection
- Ramp for trolley use

R744 MODELS (CO₂)

- The Carel version includes electronic expansion valve with accessories



BC/BF 990 SMH

Note! Ramp is available as an accessory

The requirement for trays with foodstuff is GN 1/1 trays with 65mm depth and with max. 50 mm foodstuff depth. The rule of thumb is that when halving the foodstuff depth, you double the cooling capacity kilograms.

HOTEL, RESTAURANT & CATERING

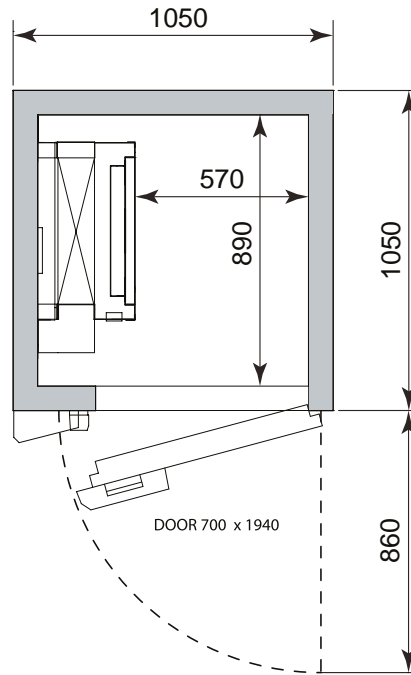

		BC AND BC/BF ROOMS			
		BC 960	BC 990	BC/BF 960	BC/BF 990
CC R452A					
CC R744					
CC R744 CAREL *****					
Cooling effect / evaporating temperature -15 °C *****	kW	7	10	7	10
Cooling effect / evaporating temperature -30 °C *****	kW	2,6	3,7	2,6	3,7
Connected power for central plant systems	kW	2,06	2,06	2,06	2,06
Voltage	V / Hz	230 / 50	230 / 50	230 / 50	230/50
Exterior width	mm	1050	1050	1050	1050
Exterior depth	mm	1050	1050	1050	1050
Exterior height	mm	2100	2100	2100	2100
Maximum trolley height recommended	mm	1800	1800	1800	1800
Ambient temperature	°C	5-32	5-32	5-32	5-32
Blast Chilling capacity 90 min.*	kg	60	90	60	90
Blast Chilling capacity 90 min.**	kg	40	60	40	60
Blast Freezing capacity 6h ***	kg	-	-	60	60
Blast Freezing capacity 2,5h ****	kg	-	-	35	50

* Blast chilling capacities have been calculated according to the English DHSS guideline using 65 mm deep GN 1/1 containers and 50 mm thick water in open containers entering at +70 to +3°C within the stated time period.

** Blast chilling capacities have been calculated using GN1/1 trays 65 mm deep trays with a product thickness of 40 mm in open containers entering at +70 to +3°C within the stated time period. Product is 87,7 % water, 11,5 % smashed potatoes powder and 0,8 % salt.

*** Blast freezing capacities have been calculated using GN1/1-65 mm deep trays with a product thickness of 50 mm from 0 to -18°C.

**** All Porkka appliances meet international standards and requirements for Blast Chilling of foodstuffs.

***** Carel version includes R744 cabinet plus Carel driver, expansion valve and solenoid valve factory installed (max. 60 bar)

***** In the sizing of the central refrigeration unit, both cooling effect demand conditions should be taken into account.

Note!

The kilograms are estimates and the realistic cooled kilograms are dependent upon the physical properties of the foodstuff and also the thickness of the foodstuff inside the container.

The evaporation temperature of the refrigerating unit connected to the BC and BC/BF rooms must be adjustable between +5°C and -35°C floating, according to the needs of the cooling process. For example, the room temperature even in the blast chilling process must be brought to the level of -20°C. This can be done, for example, by connecting the BC and BC/BF rooms to a separate constant-speed compressor (floating evaporation temperature). If a parallel-connected compressor system is used, the system must be equipped with a separate fixed-speed additional compressor, which is connected to cool the blast chilling/blast freezing object exclusively. To ensure more accurate cooling control, at least 1 compressor equipped with a frequency converter is recommended, especially when CO2 (R744) refrigerant is used. In order for the power regulation to be sufficient, the power step of the central processing unit must be dimensioned in such a way that the cooling works even with a lower cooling capacity requirement.

BC and BC/BF 24-100, BC and BC/BF 48-200

Blast chiller and blast chiller/freezer rooms for trolley operation

BC and BC/BF 24-100 and 48-200 are intended for GN 1/1 trolley operation. They are also suitable for GN 2/1 trolleys. BC/BF models have an insulated floor with an optional ramp. The models are delivered ready for a central cooling connection. The equipment requires drainage for defrost water. The range includes models for both HFC and R744 refrigerants.

FEATURES

- Soft-hard process control for blast chilling/freezing
- Controller programmed for blast chilling and freezing for 4 quick programs and with ability to store 12 customized settings
- Convenient single product probe for precise and accurate soft chilling
- Storage function
- Audible and visual local alarms for HACCP purposes
- Exterior / Interior finish and chassis in stainless steel
- HFC-free polyurethane insulation, thickness 80 mm
- Doors are supplied complete with heavy duty hinges and a lockable door handle which is complete with emergency entrapment release
- Durable gaskets provide a good air seal
- BC versions are supplied without floor, to allow simple trolley operation
- BC/BF chiller, freezer models are supplied with insulated floor equipped with a non-slip stainless steel finish
- Led light
- Electrical supply 230V/50Hz

OPTIONAL ACCESSORIES

- PORKKA BLUE combined disinfectant and lamp evaporator for disinfection
- Ramp for trolley use

R744 MODELS (CO2)

- The Carel version includes electronic expansion valve with accessories



BC/BF 48-200 SMH

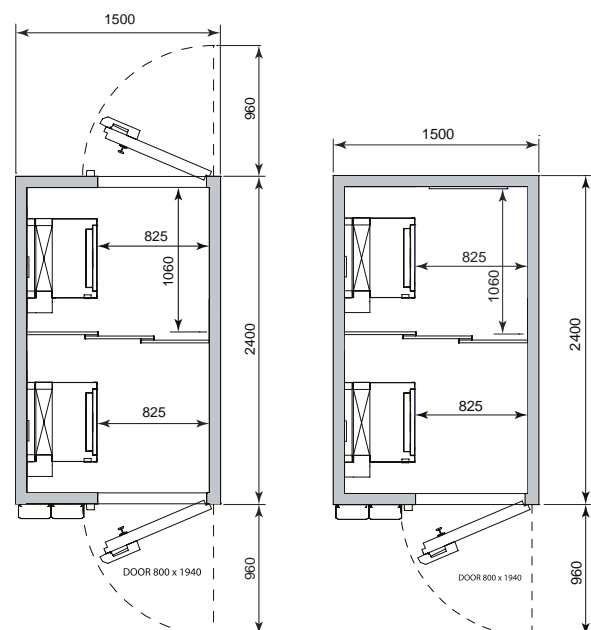

HOTEL, RESTAURANT & CATERING



BC/BF 24-100 SMH

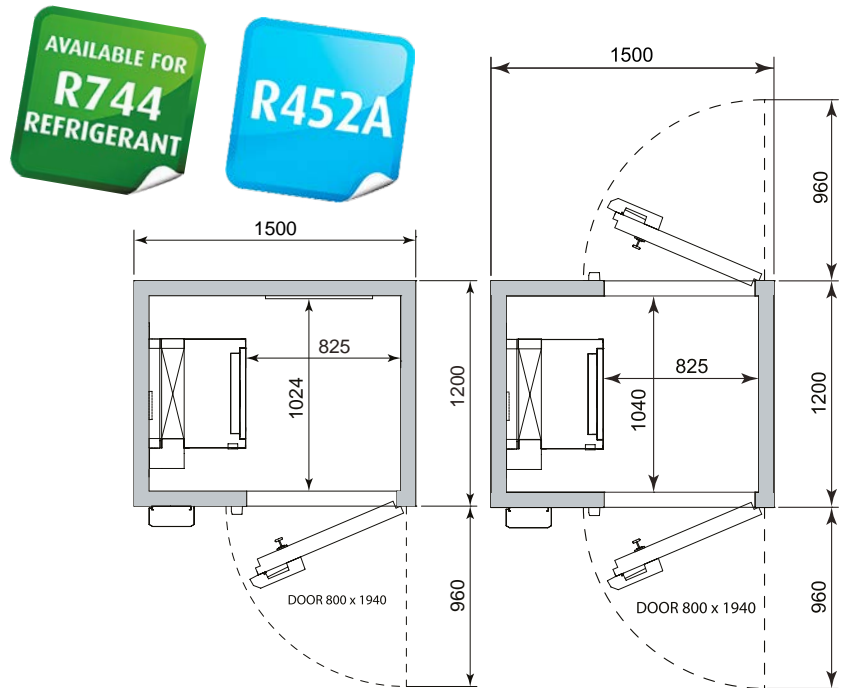

		BC AND BC/BF ROOMS			
		BC 24-100	BC 48-200	BC/BF 24-100	BC/BF 48-200
PRICE CC R452A, 1-door					
PRICE CC R452A, 2-doors					
PRICE CC R744, 1-door					
PRICE CC R744, 2-doors					
PRICE CC R744 CAREL, 1-door *****					
PRICE CC R744 CAREL, 2-doors *****					
Cooling effect / evaporating temperature -15 °C *****	kW	10	2 x 10	10	2 x 10
Cooling effect / evaporating temperature -30 °C*****	kW	3,7	2 x 3,7	3,7	2 x 3,7
Connected power for central plant systems	kW	2,1	2 x 2,1	2,1	2 x 2,1
Voltage	V / Hz	230 / 50	230 / 50	230 / 50	230/50
Exterior width	mm	1500	1500	1500	1500
Exterior depth	mm	1200	2400	1200	2400
Exterior height	mm	2100	2100	2100	2100
Maximum trolley height recommended	mm	1800	1800	1800	1800
Ambient temperature	°C	5-32	5-32	5-32	5-32
Blast Chilling capacity 90 min.*	kg	100	2 x 100	100	2 x 100
Blast Chilling capacity 90 min.**	kg	70	2 x 70	70	2 x 70
Blast Freezing capacity 6h ***	kg	-	-	100	2 x 100
Blast Freezing capacity 2,5h ****	kg	-	-	55	2 x 55

- * Blast chilling capacities have been calculated according to the English DHSS guideline using 65 mm deep GN 1/1 containers and 50 mm thick water in open containers entering at +70 to +3°C within the stated time period.
- ** Blast chilling capacities have been calculated using GN1/1 trays 65 mm deep trays with a product thickness of 40 mm in open containers entering at +70 to +3°C within the stated time period. Product is 87,7 % water, 11,5 % smashed potatoes powder and 0,8 % salt.
- *** Blast freezing capacities have been calculated using GN1/1-65 mm deep trays with a product thickness of 50 mm from 0 to -18°C .
- **** All Porkka appliances meet international standards and requirements for Blast Chilling of foodstuffs.
- ***** Carel version includes R744 cabinet plus Carel driver, expansion valve and solenoid valve factory installed (max. 60 bar)
- ***** In the sizing of the central refrigeration unit, both cooling effect demand conditions should be taken into account.

Note!
The kilograms are estimates and the realistic cooled kilograms are dependent upon the physical properties of the foodstuff and also the thickness of the foodstuff inside the container.

The evaporation temperature of the refrigerating unit connected to the BC and BC/BF rooms must be adjustable between +5°C and -35°C floating, according to the needs of the cooling process. For example, the room temperature even in the blast chilling process must be brought to the level of -20°C. This can be done, for example, by connecting the BC and BC/BF rooms to a separate constant-speed compressor (floating evaporation temperature). If a parallel-connected compressor system is used, the system must be equipped with a separate fixed-speed additional compressor, which is connected to cool the blast chilling/blast freezing object exclusively. To ensure more accurate cooling control, at least 1 compressor equipped with a frequency converter is recommended, especially when CO2 (R744) refrigerant is used. In order for the power regulation to be sufficient, the power step of the central processing unit must be dimensioned in such a way that the cooling works even with a lower cooling capacity requirement.

BC and BC/BF rooms - factory installed accessories

CODE	ACCESSORY
APM11101	LED LIGHT
VH3136	RAMP, NON-SLIP COATED - WIDTH 800/900 MM, HEIGHT 80 MM

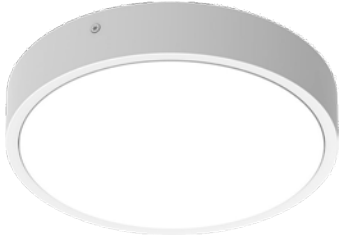

LED LIGHT



PORKKA BLUE COMBINED DISINFECTOR AND LAMP

Sales and delivery conditions

1. PRICES

All prices are exclusive of VAT. We reserve the right to adjust prices if changes in taxation, exchange rates, or other government-imposed charges affect the basis for pricing, or if costs increase due to circumstances beyond our control. The delivery term is FCA Ylöjärvi, free at our factory, or as otherwise agreed. Standard packaging is included in the prices. Upon request, freight can be quoted separately to the desired destination (this service may not be available for all regions). Prices do not include costs arising from waste management or recycling. In accordance with applicable legislation, the holder of waste is responsible for the disposal of WEEE (Waste Electrical and Electronic Equipment) when used professionally.

2. PRODUCT FEATURES

Any specifications relating to product appearance, construction, or technical properties stated in brochures are binding only if separately confirmed by the seller. Due to continuous product development, we reserve the right to make changes to the products without prior notice.

3. CHANGES AND CANCELLATIONS TO ORDERS

The buyer must notify the seller in writing of any changes or cancellations without delay. Such notifications must be received no later than 10 working days prior to the confirmed delivery date. Changes or cancellations of orders for customized products must always be separately agreed upon. The seller reserves the right to invoice the buyer for the value of the canceled or modified product based on its stage of completion, should the change or cancellation be made less than 10 working days before delivery. The new delivery time for a modified order will be calculated from the date of the requested change, unless otherwise agreed. The delivery date may be modified by the customer up to 10 working days before the confirmed delivery date; any changes after this period will not be accepted.

4. RETURNS

Returns are not accepted without prior written agreement. Any claims regarding delivered goods must be submitted within eight (8) days of receipt. All returns must be pre-approved by our representative. A maximum of 80% of the value of standard products (excluding freight) will be credited for returns not due to seller error. Freight charges are non-refundable. Return shipping is the responsibility of the customer and may be invoiced separately. The right of return applies only to standard products (excluding accessories) that are unused, undamaged, and returned in their original packaging.

5. INSURANCE

The customer is solely responsible for transport and transport insurance of the goods.

6. WARRANTIES

For export deliveries, the warranty applies solely to spare parts and is limited to ex works terms. The warranty period for export deliveries is one (1) year and sixty (60) days from the date the goods leave the factory. The warranty applies only to the original purchaser. To maintain warranty validity, the following conditions must be met:

- The product has been installed in accordance with the provided installation instructions
- The product has been used solely for its intended purpose
- The product has been operated and maintained in accordance with the instructions supplied
- Any maintenance has been performed by an authorized service provider

In the event of a defect, the seller or an authorized service provider must be contacted without delay to determine how the issue will be addressed. A defect report must include the following information:

- Brand, model, and serial number of the product
- Description of the defect and the conditions under which it occurs
- Name of the seller
- Reference number of the order, delivery note, or invoice to verify warranty eligibility

7. OTHER TERMS

These terms are subject to the provisions of Orgalime S2000, General Conditions for the Supply of Mechanical, Electrical and Electronic Products.

PORKKA

Porkka Finland Oy is an internationally recognized supplier of professional refrigeration equipment and cold and clean room solutions. Key target areas include hotels and restaurants, food industry, retail, healthcare and research and professional kitchens in the marine industry. Porkka Finland is part of the Finnish Festivo-Porkka Group.

Success of Porkka is based on decades of experience, customer-oriented design and continuous product development. Porkka products are known for their high quality, long life cycle, energy efficiency and sustainable environmental thinking. The materials used in Porkka products are as environmentally friendly and recyclable as possible. Depending on the product group, the recycling rate of products can be even 80 %.



Porkka products are designed and manufactured in accordance with international quality and environmental standards and other regulations. The management system of Porkka is certified according to standards ISO 9001:2015 and ISO 14001:2015.

We reserve the right to make changes without prior notice.

PORKKA FINLAND OY
Huurretie 13, FI-33470 YLÖJÄRVI
sales@porkka.com, www.porkka.com
Tel. +358 (0)10 201 9200

CATERCALL LTD
Aztec House
Unit 8 Perrywood Business Park
Redhill, Surrey RH1 5DZ
porkkaenquiries@catercall.co.uk
Tel. +44 1923 233675

COLIA SCANDINAVIA AB
Industrigatan 21, SE-61933 Trosa
info@colia.se, www.colia.se
Tel. +46 (0)156 348 40

COLIA AS NORWAY
Ringeriksveien 16, NO 3414 Lierstranda
post@colia.no, www.colia.no
Tel. +47 66 98 77 77